

PROXIMITY SENSOR INTERFACE

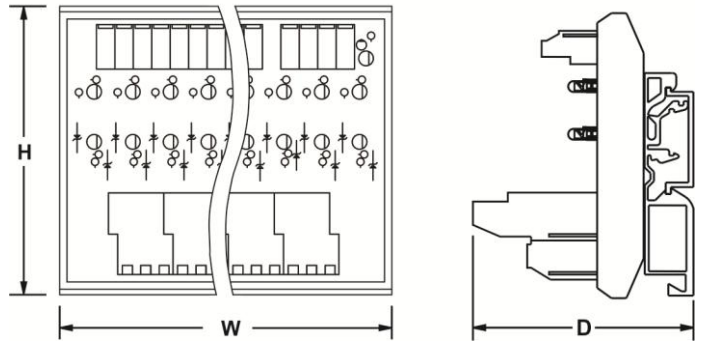

Dimensions

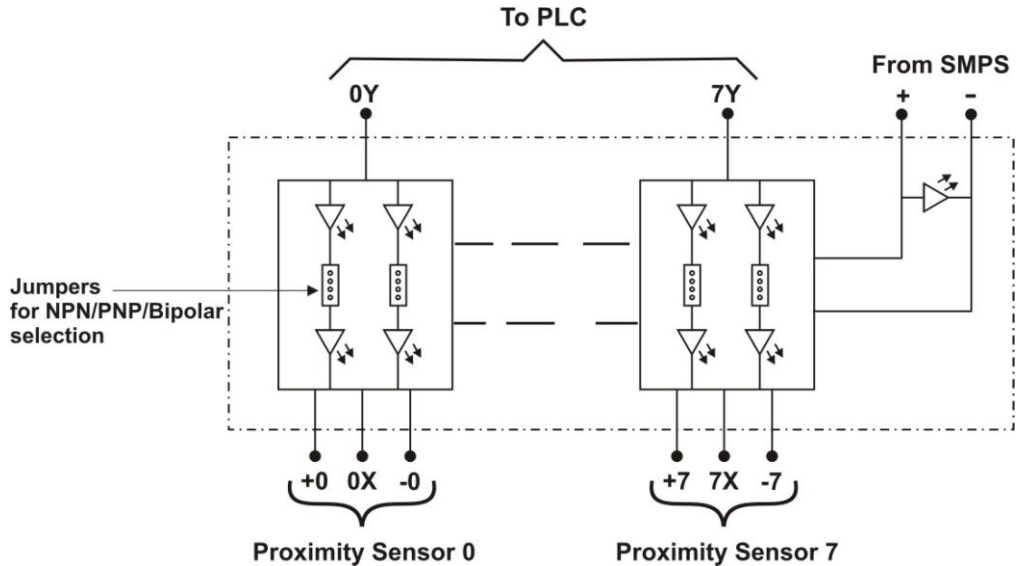

Wiring Diagram

FEATURES	<ul style="list-style-type: none"> • Grouping of Terminals for PLC Connections • Grouping of Terminals for Sensor Connections • Common Power Supply Connections • PNP, NPN or Bipolar Indication By Jumpers • 35mm DIN Rail Mountable 				
OPERATING AMBIENT	0-55°C, 85% RH				
STORAGE AMBIENT	-20°C to 85°C				
TERMINATIONS	Screw type, for 2.5mm sq. wire				
MOUNTING	35 mm DIN rail				
ORDERING INFORMATION	AS445, -24V				
	NO. OF CHANNELS	DESIGN NO.	INPUT VOLTAGE	DIMENSIONS W x H x D (mm)	WEIGHT (MAX)
	1	AS441	12V : 12VDC, 10-14VDC 24V : 24VDC, 20-28VDC	25 x 80 x 70	70 grams
	2	AS442		45 x 80 x 70	90 grams
	4	AS443		70 x 80 x 70	110 grams
	8	AS445		90 x 80 x 70	170 grams