

# RELAY MODULES WITH JUMPERS FOR COIL LOOPING

## JUMPER SETTING FOR 8 CH,1C/O MODULE AS365-XX-XX

### 1) JUMPER SETTING FOR -Ve COIL LOOPING:

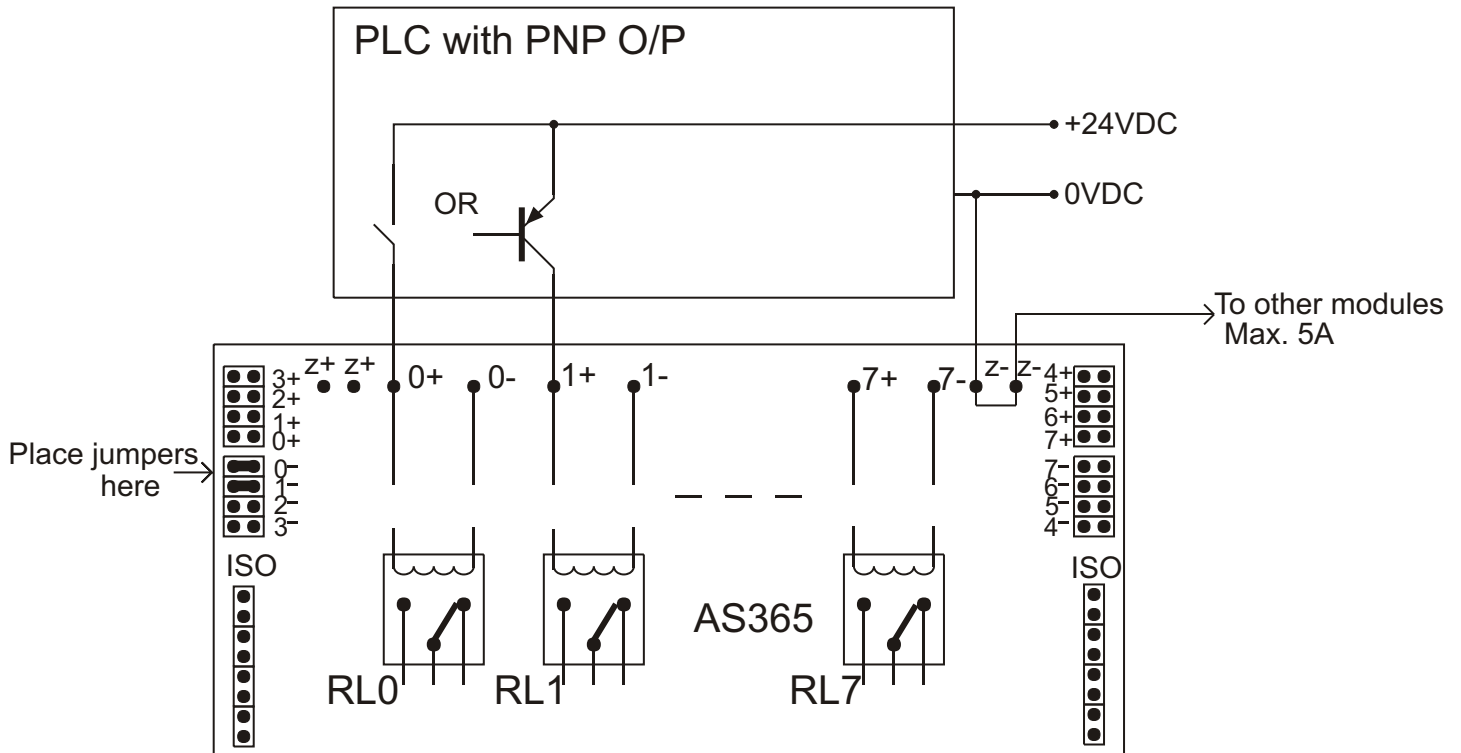

### 2) JUMPER SETTING FOR +Ve COIL LOOPING:

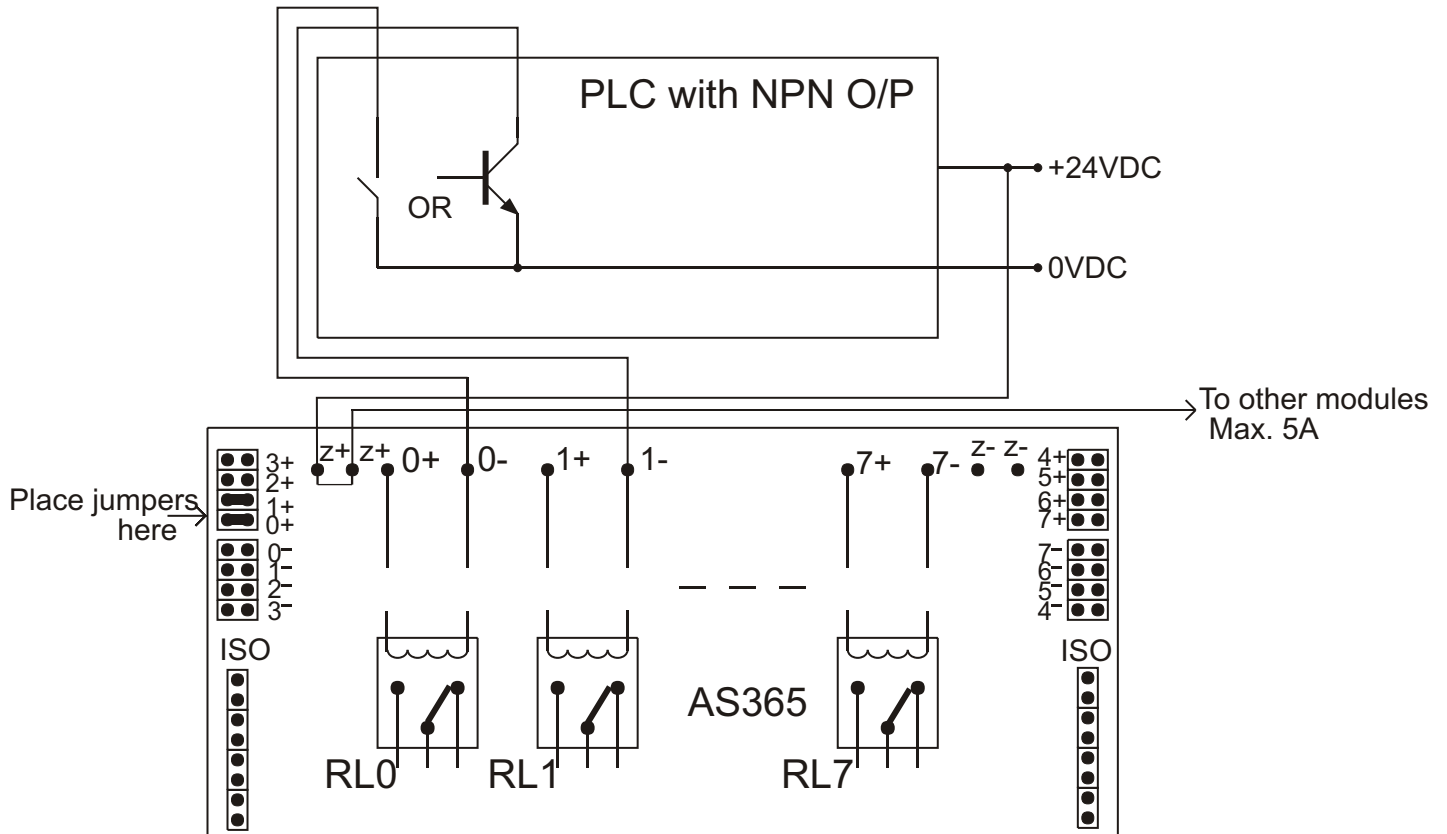

**3) JUMPER SETTING FOR ISOLATED COILS:**

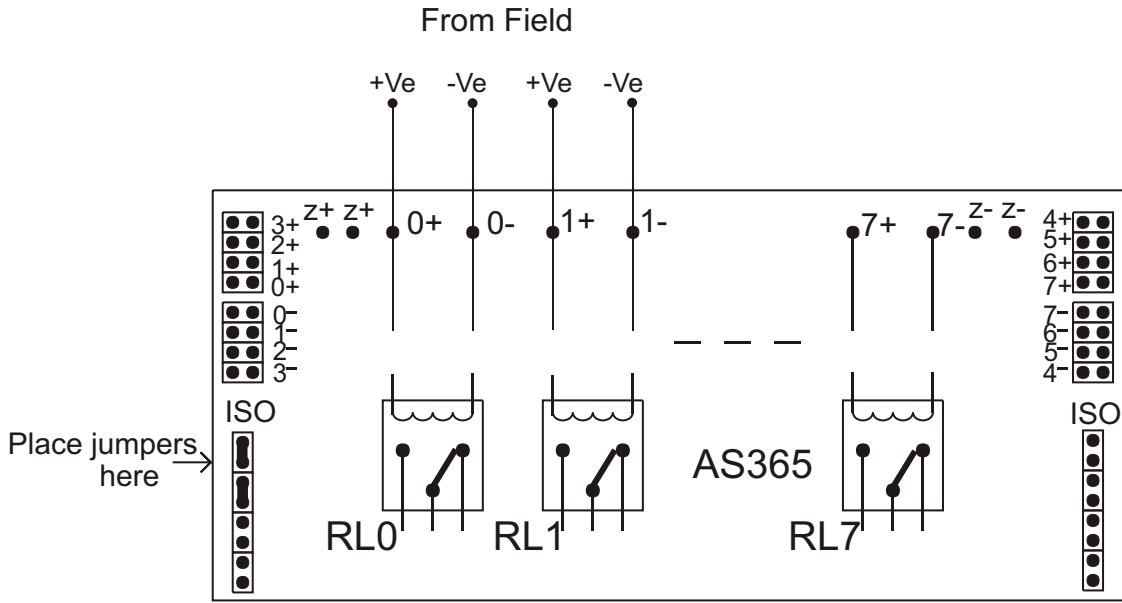

**JUMPER SETTING FOR 8 CH,2C/O MODULE AS395-XX-XX**

**1) JUMPER SETTING FOR -Ve COIL LOOPING:**

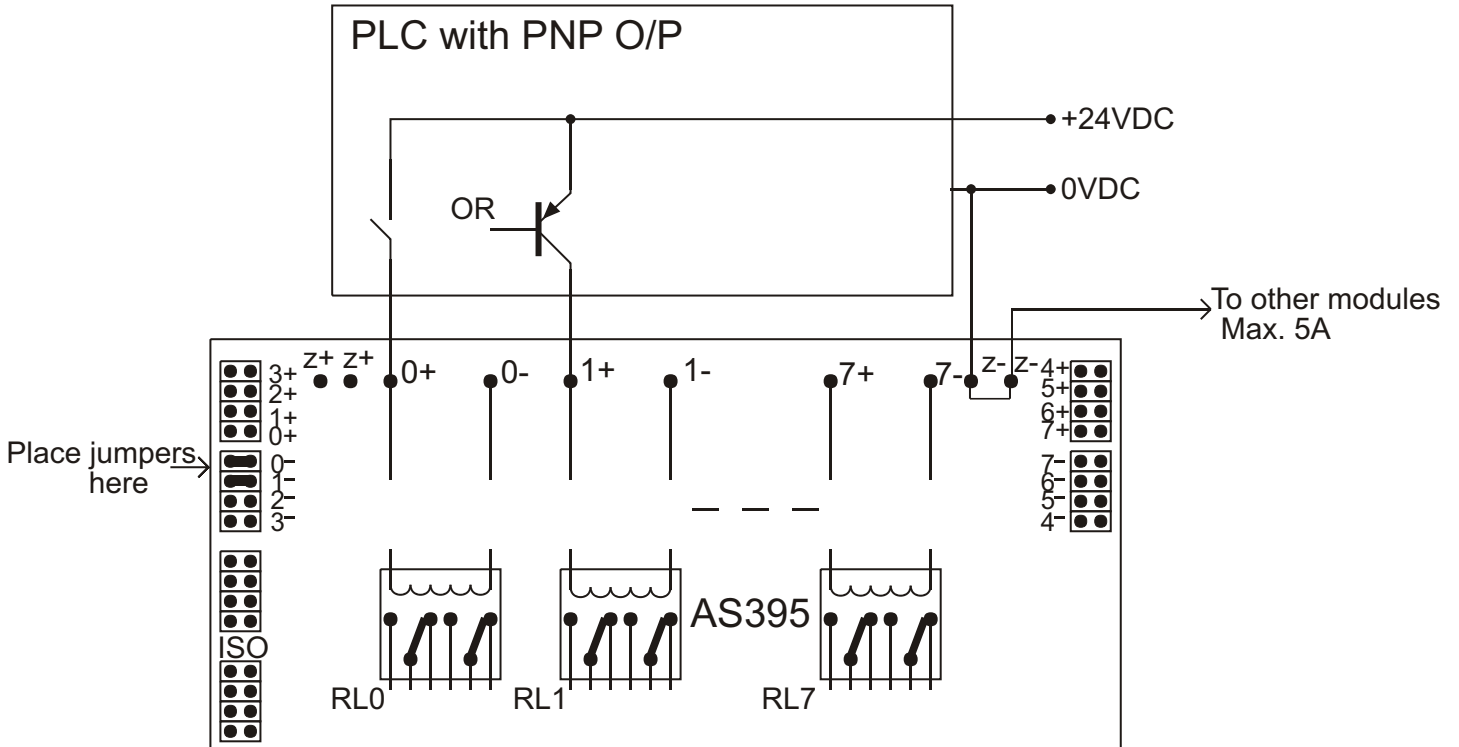

**2) JUMPER SETTING FOR +Ve COIL LOOPING:**

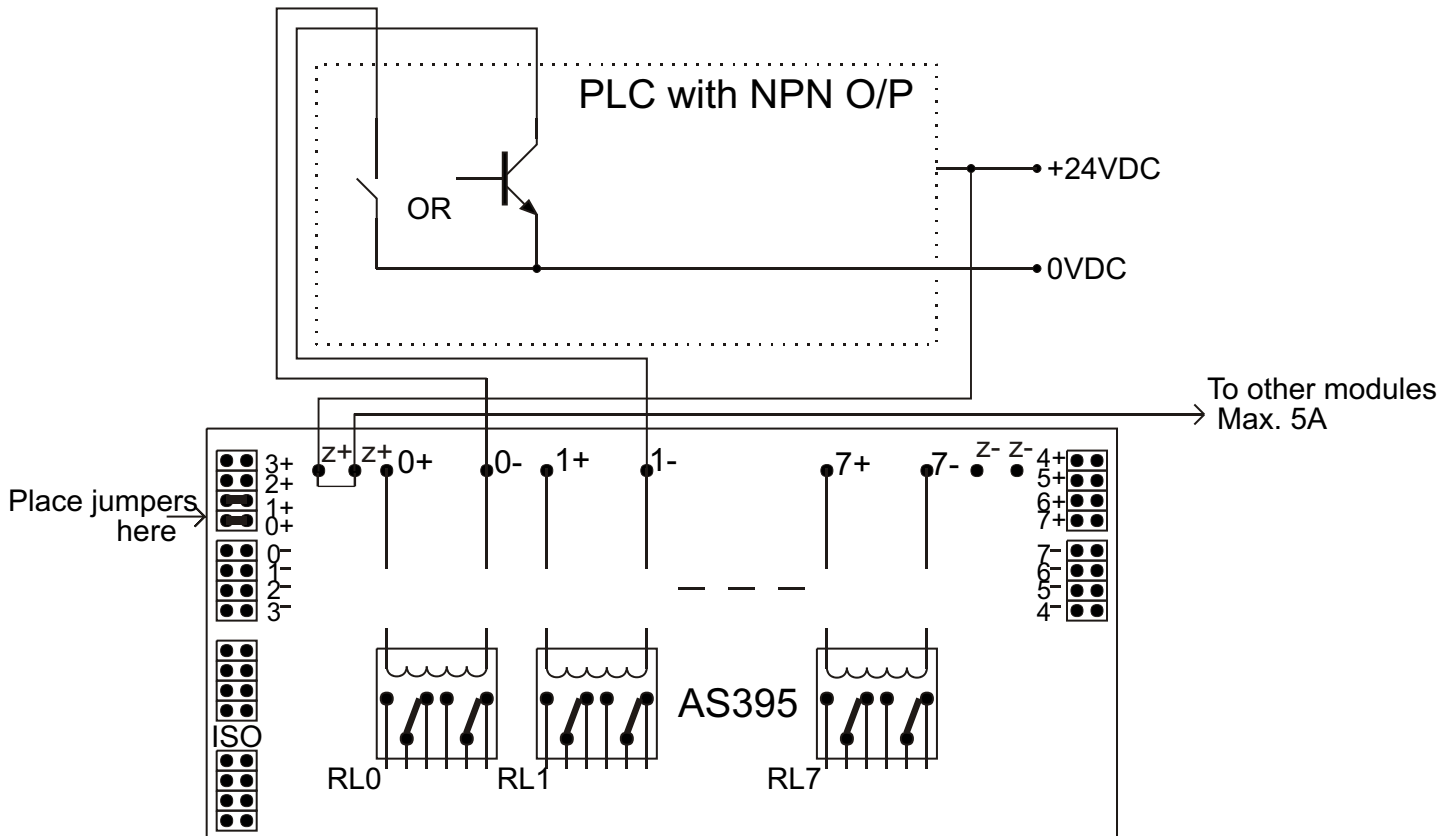

**3) JUMPER SETTING FOR ISOLATED COILS:**

